



KDF-VB

Duplex filter
with flanged butterfly valves

PN 10–64
DN 65–1.000
ANSI 2½–40"
JIS 65–1.000
GOST 65–1.000

Application areas

The KDF-VB duplex filter can be installed in pressure and in suction line and is versatile for coarse and fine filtration. It is characterized by continuous operation during the cleaning phase. The filter combines so-called housing sizes (GR) with various nominal flange connection widths (DN). The filter unit can be easily switched by a specially designed lever switch.

The KDF-VB has a combined cover and can also be delivered with bolts and nuts as well as with a quick release clamp (medium-dependent – risk analysis required). Subsequent on-site retrofitting is also possible. A danger analysis has to be performed before start up acc. PED EN 2014/68/EU or applicable codes and standards.

 Lloyd's Register
Design Appraisal
Certificate no.
HPC1461050/34963-16/TS

 Lloyd's Register
Type Approval
Certificate no. 16/20086

 DEKRA
ISO 9001:2015

Filter gemäß
 ÖNORM
ÖNORM H 5195-1

Approvals

3.1. Certificate, DGRL/TÜV, GL, LS, DNV, ABS,
TR TF/TR CU Certificates (EAC),
Lloyd's Register Type Approval Certificate No. 16/20086

 conformity evaluation according 2014/68/EU and
marking according the directive.

 Germanischer Lloyd

 Lloyd's Register

 DNV-GL

 ABS

TR TF
EAC

 Lloyd's Register



KRONEFILTER.COM
SOLUTIONS IN FILTRATION

Brief description and function

The duplex filter, comprises two identical single filters, connected via a valve-switching device with butterfly valves which can be switched to only one filter body or can be operated in parallel. Medium to be filtered enters the filter basket from the top and flows through the insert inside out. Dirt thus remains in the filter element.

As a special version, the filter is also available with star pleated strainer inserts (changed inflow of In- and Outlet).

Notice:

The compatibility between medium and vessel or sealing material is the responsibility of the operator.

The design of the pressure vessel is based on a quasi-static operation (load cycle number ≤ 1000 according to AD 2000 Merkblatt S1, section 1.4). Max. Differential pressure inlet - outlet 1 bar.

Safety instructions

Filters with clamp closure are not suitable for the filtration of hazardous media (e.g. toxic, inflammable or caustic). In such cases, bolts and nuts must be selected as closures. Generally, use of filter with switching valve must be checked for hazardous media. The use of KDF-VB filters for gases requires a review by the manufacturer.

Check the filter for intended operation prior to usage. Conformity assessment as per PED 2014/68/EU must be done for changes in operating conditions or the media (kindly contact us for the same or run a risk analysis with conformity assessment).

Commissioning

- The ball valve of the pressure equalization line between the filter bodies must be opened prior to commissioning.
- Check whether all bolts and locks have been tightened properly.
- Check the position of the switching lever. Lever points at the filter body in operation (see pict. 2).
- Fill the filter by slowly opening the shut off valve to avoid water hammer.
- Venting: The venting device fitted in the housing of each individual filter must be kept open until fluid escapes. The filter is ready-to-operate after venting the single filter body.
- Check whether the ball valve of the pressure equalization line between the filter bodies is closed after commissioning (see pict. 3).

Note:

For rubberlined units and other inserted plugs. Always counter hold with appropriate tool (open end wrench) when loosening the plug in order to avoid damage to vessel body and lining by over torque force to plug on filter vessel. Follow documentation instructions (GA drawing) ect.

Operation

Caution: Since it is a pressure vessel, it is important to ensure that the filter is without pressure prior to beginning of maintenance.

1. As soon as one filter side is dirty (increasing differential pressure on the indicator or decreasing operating pressure in the system), the clean filter side is put into operation by gradual switching.
2. **Important:** The pressure equalization line must be opened before switching. If this instruction is not followed, switching unit can get damaged.
3. Switching process: Unlock the safety bolt. Afterwards use the lever to actuate the switching slowly and switch over to other filter side. Lock the safety bolt (see pict. 4).
4. Close the pressure equalization line.



Pict. 1 – KDF-V
Stainless steel



Pict. 2 – KDF-VB
Right-hand side in operation

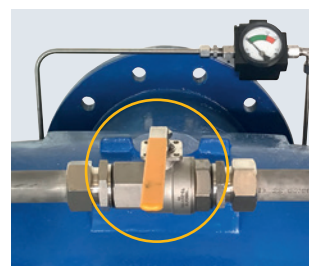

Pict. 3 – KDF-VB
Pressure equalization closed



Pict. 4 – KDF-VB
Safety bolt

- Proceed with cleaning (removal of filter element) only after opening the venting device slowly and only after releasing the pressure from the filter body which shall be cleaned (pressure equalization with atmosphere pressure). The cover can be removed. Check if the switch has closed the filter body properly and that there is no leakage. In case of leakage the process has to be stopped and the filter must be isolated via IN/OUT shut off valves.
- After opening the drain device and draining the remaining fluid from the filter side to be cleaned the strainer insert can be pulled upward and out of the filter housing for cleaning.

Caution: note maximum differential pressure of the filter (standard $D_p = 1$ bar)

Note:

For rubberlined units and other inserted plugs. Always counter hold with appropriate tool (open end wrench) when loosening the plug in order to avoid damage to vessel body and lining by over torque force to plug on filter vessel. Follow documentation instructions (GA drawing) ect.

Important information for switchover

For media having a corrosive effect on the material of the filter, switching must be actuated regularly (2–3 times) per month.

Material/housing

DIN EN GJS-500-7 / (GGG-50/ASTM 80-55-06)
alternatively annealed GJS-400-18/(GGG 40.3)

Alternative materials

Filters are alternatively available with autoclave rubber lining, in bronze, or in stainless steel SS316Ti or SS316, and many other materials for the disc of the butterfly valves like duplex SS or aluminium bronze.

- RG 10 G-CuSn(10)5
- Stainless steel
- Steel for example PGH 284, St 37.5 and others acc. ASTM

Cleaning

- The filter side to be cleaned must be depressurized (open vent carefully after switching over to the other filter side until liquid escapes).
- Then lift the cover of the filter side to be cleaned by loosening the clamp or the bolts and nuts.
- Drain the filter via the drain device to a level that is at least below the strainer support.
- Pull the strainer insert upward and out of the filter housing. The strainer can now be cleaned by careful blowing it out or blasting it with compressed air, steam, or water. If necessary the strainer must be soaked and cleaned in a suitable cleaning agent. In some circumstances optimum cleaning is achieved by means of ultrasonic bath. For all cleaning types ensure that the filter mesh is not damaged.
- Check the seals for wear during assembly, replace if necessary.

Information: Do not leave opened filters unattended and if required, keep an already cleaned reserve filter element ready for replacement.

Note:

For rubberlined units and other inserted plugs. Always counter hold with appropriate tool (open end wrench) when loosening the plug in order to avoid damage to vessel body and lining by over torque force to plug on filter vessel. Follow documentation instructions (GA drawing) ect.

KDF-VB options

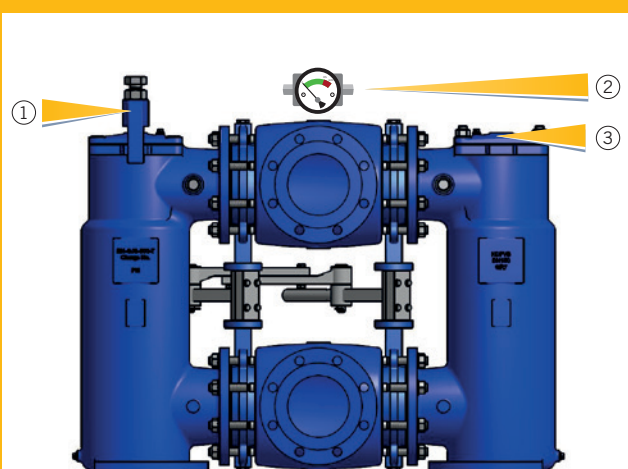

- ① Cover with clamp
- ② Option Differential pressure indicator
- ③ Cover with bolts and nuts

Technical data and dimensions

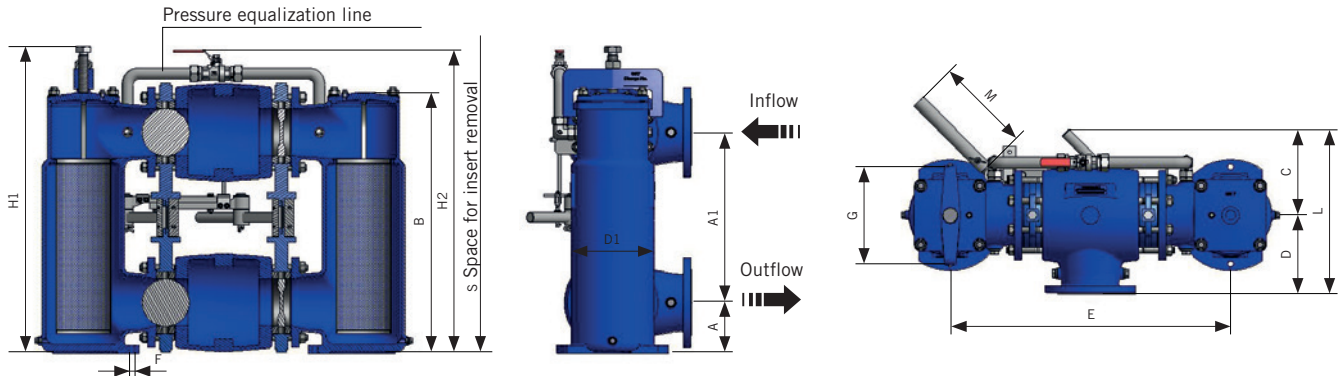

Housing	Nominal flange	Vessel design pressure		Ø D1	A	A1	B	C	D	E	F	G
Size	DN	Clamp	Bolts								Ø	Pitch
	mm	bar	bar	mm	mm	mm	mm	mm	mm	mm	mm	mm
6	65	10	16	189	160	455	767	235	250	718	18	230
	80	10	16	189	160	455	767	235	250	718	18	230
	100	10	16	189	160	455	767	235	250	718	18	230
	125	10	16	189	160	455	767	235	250	718	18	230
7	100	6	10	262	160	540	840	260	250	889	18	290
	125	6	10	262	160	540	840	260	250	889	18	290
	150	6	10	262	160	540	840	260	250	889	18	290
8	150	6	10	325	280	620	1.037	268	362	1.133	18	375
	200	6	10	325	280	620	1.037	268	362	1.133	18	375
	250	6	10	325	280	620	1.037	268	362	1.133	18	375
10	250											
	300											
	350											
11	400–1.000											

Housing	Nominal flange	S	H1	H2	L	M	Flow rate	Volume	Filter surface area			Weight
Size	DN	Strainer removal height	Height with clamp	Height with bolts	Overall length	Lever length	for 2,5 m/s		Basket strainer	Ring strainer	Star pleated strainer**	kg
	mm	mm	mm	mm	mm	mm	m³/h	L	cm²	cm²	cm²	kg
6	65	1.500	884	910	486	700	30	85	2.900	4.300	7.829**	180
	80	1.500	884	910	486	700	45	85	2.900	4.300	7.829**	180
	100	1.500	884	910	486	700	70	85	2.900	4.300	7.829**	180
	125	1.500	884	910	486	700	77	85	2.900	4.300	7.829**	180
7	100	1.550	1.150	1.000	510	500	70	105	3.030	4.370	–	385
	125	1.550	1.150	1.000	510	500	110	105	3.030	4.370	–	387
	150	1.550	1.150	1.000	510	500	160	105	3.030	4.370	–	393
8	150	2.000	1.400	1.250	642	500	160	205	4.830	5.780	–	555
	200	2.000	1.400	1.250	642	500	280	205	4.830	5.780	–	560
	250	2.000	1.400	1.250	642	500	440	205	4.830	5.780	–	567
10	250											
	300											
	350											
11	400–1.000											

Dimensions only for information – certified dimensions in approved Krone Filter Solutions installation drawing. Dimensions for welded filters differ.
 *Modification possible by means of larger filter pots. ** Star pleated strainer inserts can only be used with GR6 KDF-VB filters

Technical data

Technical data		
	Standard version	Special version and/or additional features
Filter element	Basket strainer insert	Ring type strainer, cartridges, slot wedge wire, star pleated strainer, multi mantle element
Filter mesh	10–1000 µm: Stainless steel mesh, 1,5–10 mm perforated plate with round perforation	5 µm, square perforation, braid, cartridges, pleated mesh
Filter insert dp pressure	Allowable differential pressure filter insert 1 bar	Higher allowable differential pressure for insert possible (design modification)
Filter cover	Bolts and nuts	GR 6–GR 8 clamp. Housing with clamp already predrilled for stud bolts – modification by customer possible.
Venting device	Screw	Ball valve/Flange
Draining device	Screw	Ball valve/Flange
Connection	Flange as per EN 1092-1 11B Flange position: Offset in height on same side or opposite	ANSI, JIS, as per customer specification, GOST
Materials		
Housing and cover	DIN EN GJS-500-7/(GGG-50/ASTM 80-55-06)	RG 5/10/G-CuSn(10)5ZnPb GGG-40.3/EN GJS 40-18 1.4571/316Ti steel 1.4404/316L steel
Cover seal	NBR	FPM, EPDM, PTFE
Perforated plate/mesh	SS316, SS304	SS316Ti, SS304, SS316L, Alloys, Titanium
Butterfly valves	GGG-40/1.4408/EPDM	Disc in Duplex SS, Titanium, Aluminium bronze, as per customer specification
Extras		
Additional filter	–	Magnetic filter element
Heater	–	Customized heating connection
Zinc protection	–	For sea water filter
Differential pressure indicator	–	Optical, with electrical contacts
Body/Cover Surface treatment		
Internal	Anti-corrosion primer or untreated	Anticorrosion oil, epoxy resin coating, rubber lining chemonit 33
External	Epoxy paint RAL 5010	RAL as per specification
Design/Certification		
	Declaration of Conformity – Lloyds Register certified foundry acc. to DGRL 2014/68/ EU, LR TA and LR design appraisal	3.1. Certificate, DGRL/TÜV, GL, LS, DNV, ABS, LR TA type approval, TR TF/TR CU Certificates (EAC) or on request

Accessories

We produce and deliver additional design and material variants on request.
We solicit your request.



Differential pressure indicator
<http://www.krone-filter.com/product.php?id=13>



KDF-V PN 64/DN 150



KDF-V DN 500/20*

KDF-VB spare part sets

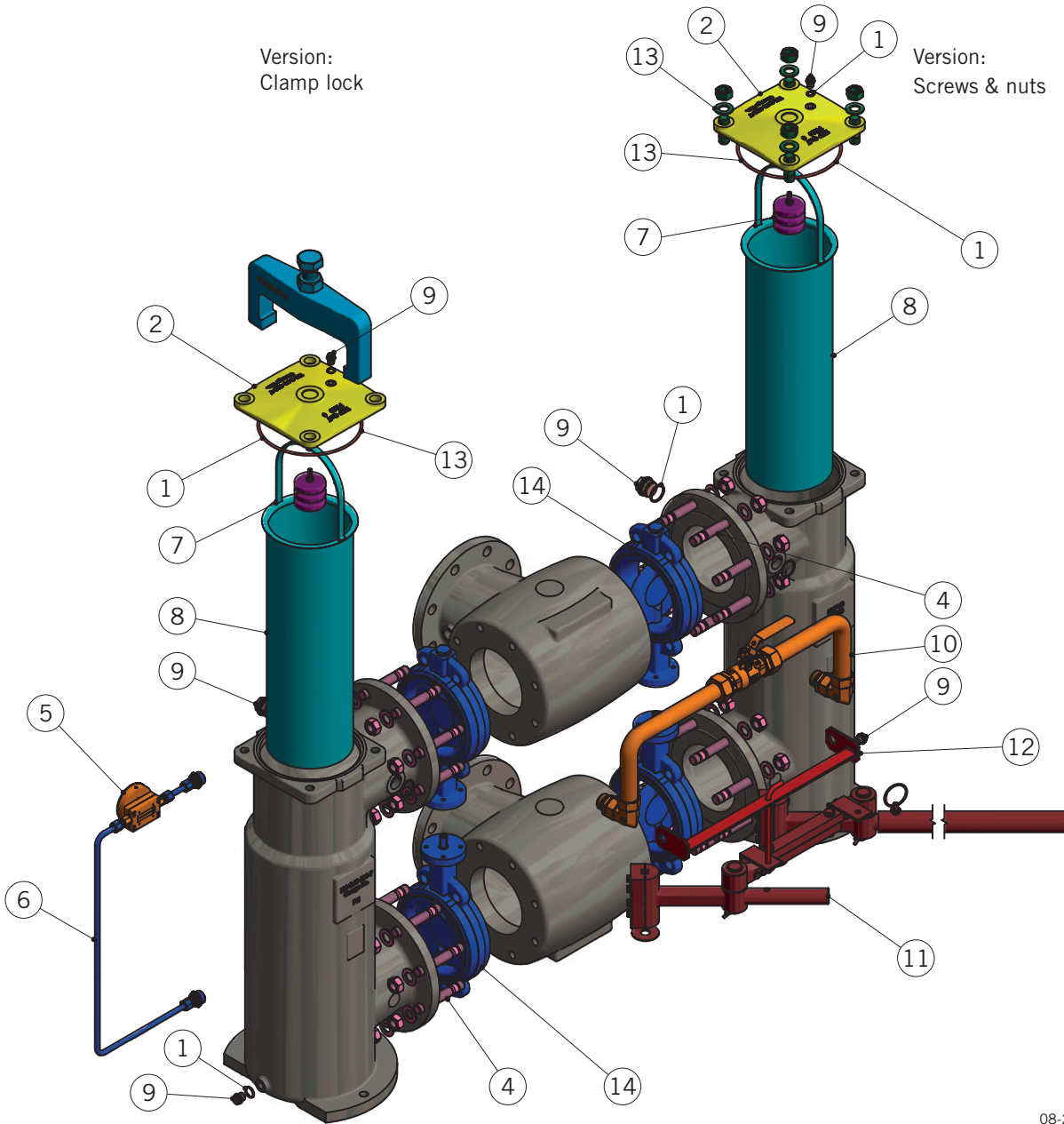

08-2023

Spare parts set for KDF-VB & KDWF-VB		Spare parts set for KDF-VB & KDWF-VB	
Set	Content	Set	Content
Spare parts set 1	Gaskets	Spare parts set 8	Insert
Spare parts set 2	Cover	Spare parts set 9	Plugs: Vent, Drain, equalization line, DP Connection
Spare parts set 3	Bolts, nuts & washer for cover	Spare parts set 10	Pressure equalization line
Spare parts set 4	Bolts, nuts & washer for switchover housing	Spare parts set 11	Switching lever
Spare parts set 5	DP Indicator	Spare parts set 12	Adjustment notch for switching lever
Spare parts set 6	Mounting kit for DP Indicator	Spare parts set 13	Cover gasket
Spare parts set 7	Magnetic filter insert	Spare parts set 14	Butterfly valves

Overview of our Filter Types

Self cleaning filter



- KAF® Self cleaning Bernoulli®-filter
- KAF-G
- KAF-S
- KRF Backflush-filter
- KAS Scraper filter

Single filter

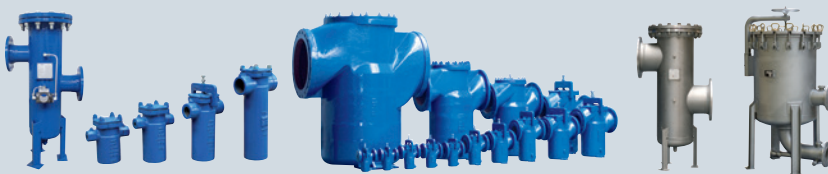

- KSF® Single basket filter (flanged)
- KMF Threaded basket filter
- KWF Welded/custom made basket filter
- KWF-Inline Inlet flange and outlet flange inline

Duplex filter



- KDF-K Duplex filter
- KDF-V Valve switch duplex filter
- KDF-VB Butterfly valve switch filter
- KDF-W Duplex filter

Other filter solutions

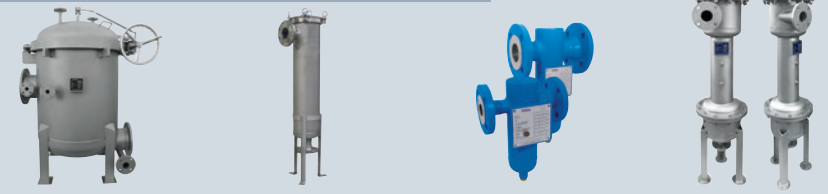

- KBF Bag filter
- KBF-M Multi-Bag filter
- KOW Oil and water separator
- KCS Centrifugal separator

Accessoires

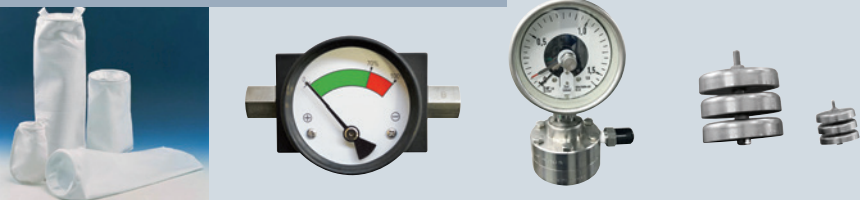

- DeltaP Differential pressure indicator
- Contaminant level indicator
- Filterbags
- Magnets

Filter elements



- Basket elements
- Ring elements
- Star-pleated elements
- Wedge wire elements
- GRP/FRP PP inserts
- Custom-made elements



Krone Filter Solutions GmbH

Industriestrasse 19 | 28876 Oyten/Germany
Phone +49 4207 98769-0 | Fax +49 4207 98769-27
filter@krone-filter.com | www.krone-filter.com
www.krone-filtershop24.com

**KRONE***FILTER*.COM
SOLUTIONS IN FILTRATION

Type Approval Certificate

This is to certify that the undernoted product(s) has/have been tested with satisfactory results in accordance with the relevant requirements of the Lloyd's Register Type Approval System.

Manufacturer	Krone Filter Solutions GmbH
Address	Industriestr. 19, Oyten, 28876, Germany
Type	Automatic self-cleaning and basket filters
Description	Single, duplex and self-cleaning automatic filter with several housing sizes and combinations made from standard materials spheroidal iron castings EN-GJS-500-7 (GGG 50)* or EN-GJS-400-15 (GGG 40), carbon steel optional rubber lined or stainless steel.
Trade Name	KSF, KMF, KDF-K, KDF-V, KAF, KAF-S, KAF-G, KRF
Application	Filter depending on type for diesel oil, oil or water piping systems in ship and offshore installations classed or intended for Classification with Lloyd's Register.
Specified Standard	Lloyd's Register Rules and Regulations for the Classification of Ships, July 2021
Other Conditions	The manufacturer's installation instructions are to be sought. *) Not to be used for applications with expected significant chock or vibration loads.



Torsten Schroeder

Senior Specialist to Lloyd's Register EMEA
A member of the Lloyd's Register group

71 Fenchurch Street, London, EC3M 4BS, United Kingdom

Lloyd's Register Group Limited, its affiliates and subsidiaries and their respective officers, employees or agents are, individually and collectively, referred to in this clause as 'Lloyd's Register'. Lloyd's Register assumes no responsibility and shall not be liable to any person for any loss, damage or expense caused by reliance on the information or advice in this document or howsoever provided, unless that person has signed a contract with the relevant Lloyd's Register entity for the provision of this information or advice and in that case any responsibility or liability is exclusively on the terms and conditions set out in that contract.

Type Approval Certificate

This certificate is not valid for equipment, the design, ratings or operating parameters of which have been varied from the specimen tested. The manufacturer should notify Lloyd's Register EMEA of any modification or changes to the equipment in order to obtain a valid Certificate.

Previous Version: 16/20086

The Design Appraisal Document HTS/ENS 34963-16, Issue 1 and its supplementary Type Approval Terms and Conditions form part of this Certificate.

71 Fenchurch Street, London, EC3M 4BS, United
Kingdom

Lloyd's Register Group Limited, its affiliates and subsidiaries and their respective officers, employees or agents are, individually and collectively, referred to in this clause as 'Lloyd's Register'. Lloyd's Register assumes no responsibility and shall not be liable to any person for any loss, damage or expense caused by reliance on the information or advice in this document or howsoever provided, unless that person has signed a contract with the relevant Lloyd's Register entity for the provision of this information or advice and in that case any responsibility or liability is exclusively on the terms and conditions set out in that contract.

Appendix

RATINGS	Filter type:	Nominal pressures: [bar]	Size range:	Material:
	KSF	6, 10, 25	DN 15 – DN 600	Spheroidal iron casting
	KMF	6, 10, 25	G ½” – 2 ½”	Spheroidal iron casting
	KDF-K	6, 10, 25	DN 15 – DN 250	Spheroidal iron casting
	KDF-V	6, 10, 25	DN 100 – DN 600	Spheroidal iron casting, carbon steel
	KRF	6, 10	DN 32 – DN 400	Spheroidal iron casting, carbon steel
	KAF	6, 10	DN 50 – DN 1000	Spheroidal iron casting, carbon or stainless steel,
	KAF-S	6, 10	DN 50 – DN 1000	Spheroidal iron casting, carbon or stainless steel,
	KAF-G	6, 10	DN 50 – DN 1000	Spheroidal iron casting, carbon or stainless steel,

Material:	Temperature range:	For fluids**:
Spheroidal cast iron	-10 up to +300°C	MDO, HFO, oil, water, seawater
Austenitic stainless steel: 1.4571, 1.4401, 1.4404, 1.4408, 1.4539, 1.4301, 1.4541, SA240-304L, SA240-316Ti, SA240-321, SA240-316L, SA240-904L,	-196 up to +300°C	MDO, HFO, oil, nitrogen
Duplex stainless steel: 1.4462, 1.4463, UNS S31803	-40 up to +250°C	seawater
Super duplex: 1.4410, UNS 32750		
Carbon steel: St 50, P235GH, P245GH, P250GH, P265GH, SA516 Gr60, SA516 Gr70	-40 up to +100°C	MDO, HFO, oil, water, seawater

**) including fluids and mixture of similar evaluation class

Pressure reductions at elevated temperatures are to be considered.

Media depending on type: KAF, KAF-S, KAF-G, KRF: water, seawater

KSF, KMF, KDF-K and KDF-V: MDO, oil, nitrogen, water, seawater

LLOYD'S REGISTER TYPE APPROVAL – DESIGN APPRAISAL DOCUMENT

Issued by: Hamburg Technical Support Office (HPC 1461050)

Issued to: KRONE FILTER SOLUTIONS GMBH

For: SINGLE, DUPLEX AND AUTOMATIC FILTER

Types: KSF, KMF, KDF-K, KDF-V, KAF, KAF-S, KAF-G, KRF

The undernoted documents have been reviewed for compliance with the requirements of the Lloyd's Register Type Approval System Procedure TA14 Version 04 (September 2020) and this Design Appraisal Document forms part of the Certificate.

APPROVAL DOCUMENTATION

-	Application Checklist	19.05.2021
16/20086	Previous Type Approval Certificate	09.09.2016
-	Product Catalogue / general Data sheets for types KSF, KMF, KDFK, KDFV, KDF and KRF	2014
KSF LR Data sheet, Rev. 4	KSF	2016
KSF080.04.16.00.01, Rev. 0	AW 613 PN16 DN 80 incl. Parts list	22.04.2008
KSF80.04.16.01.01, Rev. 1	Body DN 80 GR4	10.03.2006
KSF000.05.16.02.01, Rev. 0	Cover GR5	25.03.2009
KMF LR Data sheet, Rev. 4	KMF	2016
KMF000.03.05.16.00.01, Rev 0	KMF GR3 incl. Parts list	22.11.2013
KMF000.03.05.16.01.01, Rev 0	Body KMF GR3 / GR1 ½" – G2"	22.11.2013
KSF000.03.05.16.02.01, Rev.1	KSF Cover GR3	24.11.2011
KDFK LR Data sheet, Rev. 4	KDFK	2016
KDFK080.06.05.10.00.01, Rev. 0	KDFK DN 80 PN 10 incl. Parts list	24.02.2011
KDFK080.04.05.10.01.02, Rev.2	KDFK Body GR4 DN 80 PN10 JIS 10K	20.03.2014
KSF000.06.10.02.01, Rev. 0	Cover GR6	31.03.2009
KDFK250.07.05.10.00.01	KDF-K Double filter DN 250 PN 16	23.10.2019
KDFK250.07.05.10.01.01	KSF Body DN 250 PN 10 Gr. 7	23.10.2019
KSF00.08.05.10.02.01, rev. 1	Cover KSF Gr.8	01.04.2009
KDFV LR Data sheet, Rev. 2	KDFV	2016
KDFV150.07.05.10.00.20, Rev 1	KDFV GR7 DN 150 incl. Parts list	12.07.2012
KDFV150.07.05.10.01.20, Rev 1	KDFV Body GR7 DN 150	27.04.2012
KDFV150.07.05.16.08.20, Rev 4	KDFV Body Change Over GR7 DN 150	12.07.2012
KSF000.07.05.10.02.01, Rev. 0	Cover GR7	24.02.2011
KAF LR Data sheet, Rev. 0	KAF	2016
KAF150.01.16.05.00.01, Rev. 0	KAF DN 150 PN5 JIS B 2220 K5 FF incl. Parts list	16.05.2014
KAF150.00.05.05.01.02, Rev. 0	Body KAF DN 150 PN5	16.05.2014
KAF150.00.16.05.01.02, Rev. 0	Body KAF DN 150 PN5 rubber lined incl. Parts list	16.05.2014
KAF150.00.05.10.02.01, Rev. 0	KAF Cover DN 150 PN 19 / DNC-50	12.12.2013
KAF150.00.16.10.02.01, Rev. 0	KAF Cover DN 150 PN 19 / DNC-50 incl. Parts list	12.12.2013
KRF LR Data sheet, Rev. 4	KRF-BF	2016

TEST REPORTS

-	Production Quality Assessment in Oyten	30.06.2021
HPC1461050/01	LR Works Inspection including hydrostatic burst pressure tests at 100 bar for type KSF: DN 50, size 2; KSF: DN 80, size 4 and KSF: DN 100, size 8	14.12.2015
HPC1461050/02	hydrostatic burst pressure tests at 100 bar for type KMF: 2 ½" size 4; type KDF-K : DN 80, size 6 and KDF-K: DN 20, size 2 witnessed by LR Surveyor at Krone in Oyten	17.12.2015
HPC1461050/03	hydrostatic burst pressure tests at 40 bar for type KAF: DN 200, PN 10 and at 64 bar for type KDF-V: DN 150, size 7, PN 16 witnessed by LR Surveyor at Krone in Oyten	21.12.2015
HPC1461050/04	Visit of an existing installation with function test of KAF self-cleaning automatic filter at 'Elbphilharmonie Hamburg'	11.01.2016



Torsten Schröder
Senior Specialist
Engineering Systems
Hamburg Technical Support Office
Lloyd's Register EMEA
T +49 (0)40 349 700 10 259
E torsten.schroeder@lr.org

Supplementary Type Approval Terms and Conditions

Type Approval certifies that a representative sample of the product(s) referred to herein has/have been found to meet the applicable design criteria for the use specified herein. It does not mean or imply approval for any other use, nor approval of any product(s) designed or manufactured otherwise than in strict conformity with the said representative sample.

Type Approval is based on the understanding that the manufacturer's recommendations and instructions and any relevant requirements of the Rules and Regulations are complied with.

Type Approval does not eliminate the need for normal inspection and survey procedures required by the Rules and Regulations. Lloyd's Register EMEA reserves the right to cancel or withdraw this Type Approval Certificate in accordance with the Lloyd's Register Type Approval System Procedure.